

# Bacon Bits

Flying Pigs QRP Club International, W8PIG  
 1900 Pittsfield St, Kettering, Ohio 45420

E-mail: [w8pig@yahoo.com](mailto:w8pig@yahoo.com) Web Page: <http://www.fpqrp.com>

FPQRP [membership](#) is open to all licensed QRP operators who reside within 12,000 nautical miles of Cincinnati, Ohio.

### CONTACTS:

Diz, W8DIZ  
[w8diz@cinci.rr.com](mailto:w8diz@cinci.rr.com)  
 Rick, WB6JBM  
[ripowell@mpna.com](mailto:ripowell@mpna.com)  
 Dan, N8IE [n8ie@who.rr.com](mailto:n8ie@who.rr.com)  
 Brian, KB9BVN [kb9bvn@arrl.net](mailto:kb9bvn@arrl.net)

### NETS:

DAY	TIME	FREQ	NCI
Sun	0100Z	7.137	
KC8NYW			
Mon	0100Z	7.044	WB8ICN
Thurs	0100Z	7.044	KE1LA

### CLUB FREQS.

1,814 kHz	3,564 kHz
7,044 kHz	10,110 kHz
14,062 kHz	18,100 kHz
21,064 kHz	24,910 kHz
28,064 kHz	

ALL FPqrp frequencies are UP 4 kHz from the standard qrp frequencies except for 20 meters.

(All days/times listed are UTC)

## Super Blue Mixer

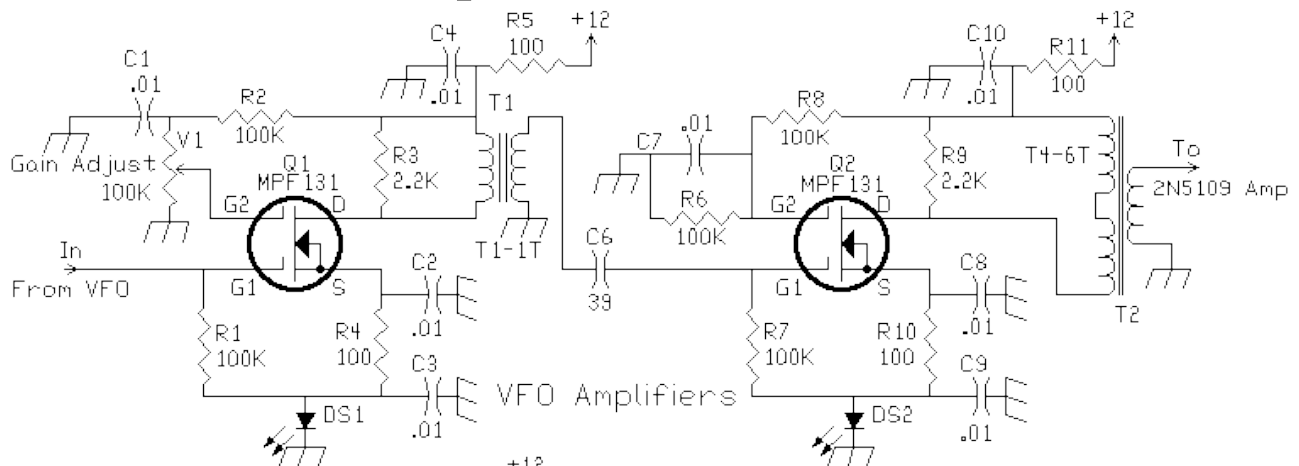

### 10.455 MHz

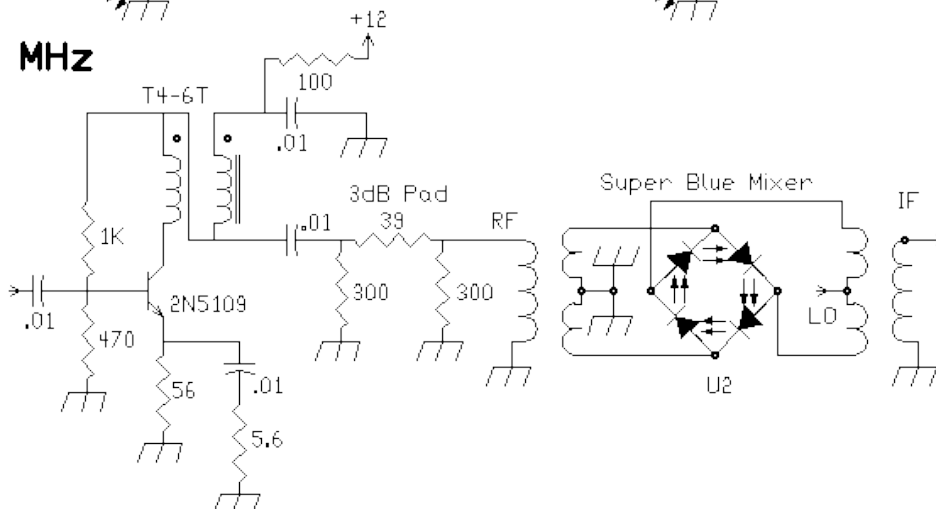

## In this issue:

Pig Droppings- Mike KD5KXF	Page 2
Super Blue Mixer – David WN5Y	Page 2
American QRP Club Forum Schedule- Doug KI6DA	Page 5
Farewell QRP L-Mike KD5KXF	Page 5
QRP RX- John W2AGN	Page 6
Info about the Flying Pigs:	Page 7

### Pig Droppings

Sorry for the delay in getting my first issue out to you patient folks and I really appreciate the lack of threatening emails from you. Well here it is... in all it's glory.

Let me introduce myself, I am Mike KD5KXF FP# 214 and I will be your Bacon Bits editor this year unless I am ousted sooner. Some of you have met me and know me, others soon will find out what those people already know... I am a pig.

This issue is pretty light on articles, but the ones I have are pretty darn good! Thanks to everyone who submitted. My personal email is [kd5kxf@classicnet.net](mailto:kd5kxf@classicnet.net) so if you have anything for the Bacon Bits email it to me there.

Winter finally reached the Dallas TX area this weekend and we had snow. There is something about cold weather that makes me want to play with receivers and listen to shortwave broadcasts. Apparently, I am not the only one. Seems like there have been lot's of interesting receiver projects going around on the email reflectors.

73 de KD5KXF

**Super Blue Mixer By David White, WN5Y**



Out of the pig wallow, past the feeding trough, into the feeding bucket, and tracked into the hamshack on shoes full of pig poop, was an idea that I thought was crazy. A friend from Australia, Pascal Nguyen, sent me an email with the following information:

“My suggestion is to replace the mixer with passive LED type. Please find more information from US patent 6,111,452. [1] It is a wideband gap SiC material; it means high mobility for electrons. Simply speaking it is a ring diode mixer with all diodes replaced by blue LEDs. I built this type of mixer in 1998 but only with red LED to convert my 500kHz to audio. ...It was designed for High IP3 and jamming warfare by the US forces.”

All the know- it- alls forecasted it probably wouldn't work because of the high forward voltage drop of the super bright LEDs. However, there was this picture of Nguyen's product detector with four brightly- lighted LEDs claiming very good performance. [2]

Finally, I tried the idea. It worked, and works very well indeed! After studying the patent and hearing the performance in my home-brew receiver, this modification turns out to be a very easy upgrade for homebrew double balanced diode mixers. [3]

### The Proof in the Poop

One of the ways to improve diode mixers is to use additional diodes in each leg of the mixer. This also raises the forward voltage drop in each leg, which proves that a higher voltage drop in a diode string does not stop a diode mixer from working. However, the higher forward voltage drop does increase the drive needed to make the mixer work.

“Current methods to increase the saturated output level of mixers and thereby reduce IMD products have focused on increasing the LO power level of the device by increasing the number of diodes used in the mixer circuit. ... Fabrication and matching of multiple diodes, however, is difficult and timely, thus increasing the cost of such multiple- diode mixers.” [5]

As stated above, additional diodes must be matched for good performance: a difficult job when using 1N4148/1N914s common in most hamshacks. The patent states, “...it is now possible to use wide bandgap diodes, such as silicon carbide or GaN, to obtain similar or better performance since only two diodes are needed, instead of the twelve conventional diodes it takes to achieve the same diode turn- on and resulting IMD levels.” [4]

The patent notes four materials from which wide bandgap semiconductor diodes are made. They are SiC, GaN, diamond, and AlGaN. Blue LEDs are made of GaN and are widely available from electronic stores and some surplus outlets. [6]

So the obvious conclusion quoted from the patent: “...The use of wide bandgap semiconductors will permit RF mixers to operate in higher RF environments, to be less susceptible to out- of- band jamming and interference, and to be more effective in receiving weak RF signals in the presence of strong unwanted signals.” [7]

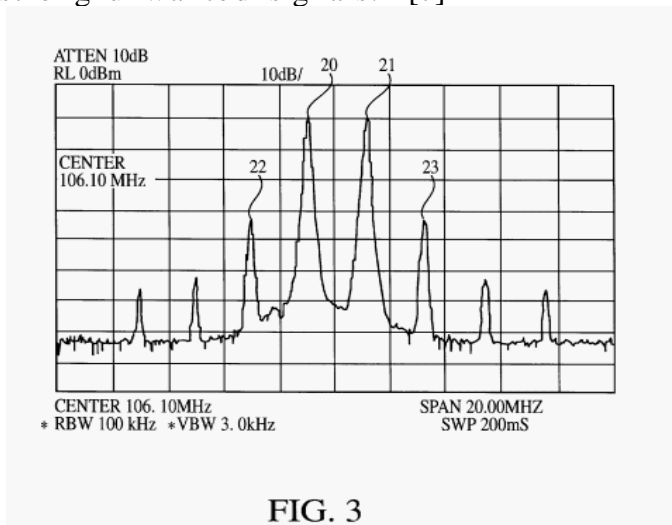

FIG. 3

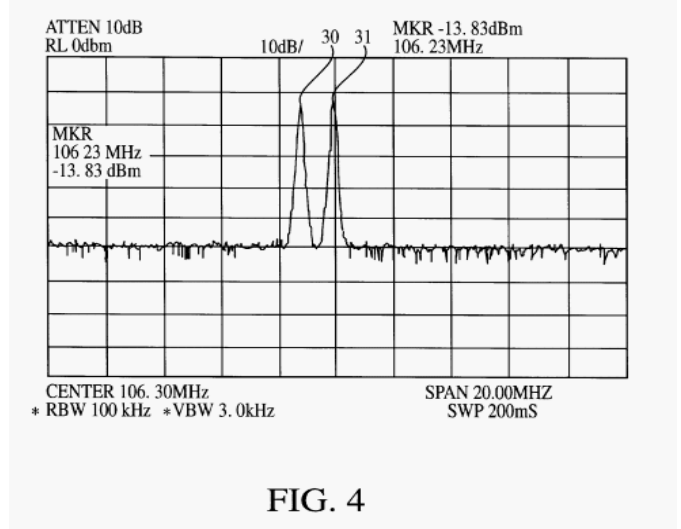

FIG. 4

Fig. 3 is a spectrum analyzer output from the patent information showing the typical output of a silicon diode mixer. Fig. 4 is a spectrum analyzer output using SiC diodes in the same environment. The LO power in Fig. 4 is 20dB higher to provide the same 10dB loss because of the higher turn- on voltage needed for the SiC diodes. The results from blue LEDs should be similar. Note that the 3<sup>rd</sup> order products have disappeared!

### Getting the Methane from the Poop

Practical applications of the previous information are quick and easy, with the additional benefit that the drive levels to the mixer are shown in the brightness of the LEDs. Also, using a VFO drive level control allows an operator to vary the signal loss through the mixer allowing visual adjustments for varying band conditions.

Pic. 1 shows a homebrew double balanced silicon diode mixer using 1N914s and FT50- 43 ferrite cores built using the information from reference [3]. Pic. 2 shows the LEDs installed. A very simple modification: replace the silicon diodes with super bright blue LEDs. The flat side of the LED goes to the same side as the band (cathode) of the diodes.

The drive level needed for the modified

mixer depends on the frequency. I tested the modified mixer at two frequencies: a double balanced diode product detector used in the Electroluminescent Receiver Kit (ELR) [8] at 455 kHz, and a double balanced mixer used in my Super Receiver with a 10.455 MHz VFO receiving the 20 meter band (14 Mhz).

The diodes in the ELR product detector were replaced with bright red LEDs, just like in Nguyen's paper, and it worked first time. With no modifications to the drive level, the LEDs were bright and the audio sounded great. (The red LEDs used were labeled "Bright Reds" (2000mcd) with a forward voltage drop of 1.5 to 2.0 volts typical of most LEDs. The super bright blues have a forward voltage drop of 3.5 to 4 volts.)

Then super bright blue LEDs were installed and were dimly lit. All the coupling caps between the Hartley BFO, variable gain MOSFET amplifier and product detector were changed to a .01 disc. The blue LEDs were at full brilliance when the receiver was fired up.

The variable gain MOSFET amplifier was adjusted between having the product detector LEDs completely dark to full brilliance. Just when the LEDs went out, there was no audio. But just at that point where some light could be seen, audio was present. There was very little difference between just barely lit and full brilliance in the audio output.

With no modifications to the Super Receiver, when super bright blue LEDs were dropped into the mixer, the LEDs were dark. Following the patent's suggestion of 20dB more gain for the mixer, I added a 2N5109 amplifier with a 50 ohm pad at the output, adding about 16 to 18dB of drive to the VFO. The LEDs were brightly lit after this modification. The resultant amplifier chain consisted of a variable gain MOSFET amp, a regular MOSFET amp, and the 2N5109 amp.

With the blue LEDs barely lit, the receiver had a loss of gain over the silicon mixer (SBL-3), but when the LEDs were at full

brilliance, there was no difference between the silicon mixer and the modified blue LED mixer. After a subjective evaluation, using the receiver for a few DX contacts, performance seemed to be enhanced.

Red LEDs were tried and worked well with only the MOSFET amplifiers; the red mixer did not need the 2N5109 amp.

### **Something Goin' on Weird in this Hamshack**

Tests measuring the Super Blue Mixer for IP3 haven't been made, but the information from the patent clearly indicates superior performance with blue LEDs.

There are a couple of advantages to using LEDs in a diode mixer outside of improved performance. First, maximum performance is guaranteed when the LEDs are at full brilliance, or nearly full. Second, easy diagnosis of the VFO and amplifier chain: no light - no oscillation or a dead amplifier. The LEDs give confidence that the mixer is performing at its maximum without the use of any test equipment.

The Super Blue Mixer is so bright that blue light leaks out all around the base of my receiver. I just don't know why visitors choose the chair at the opposite side of the room to sit. Methane gas is supposed to be odorless. Between CW characters I hear words like "alien", "spacecraft", "strange" - I assume it must be some region 2 interference.

Henceforth, all you pigs now know all about the four blue LEDs on the cover of the latest QRP Quarterly, and can show extreme intelligence when someone asks, "What are those for? He didn't mention them in the text!"

If you can't remember "wide bandgap diodes", Silicon Carbide, AlGaIn, GaN blue LEDs, or high IP3 intercept point, don't get choked up. Just start out, "I heard a story about an alien spaceship that crash landed

next to a pig wallow...”.

WN5Y

---

[1]

<http://www.grc.nasa.gov/WWW/SiC/pubpatentindex.html>, US Patent 6,111,452 Wide dynamic range RF mixers using wide bandgap semiconductors

[2] His paper is on my web site in .pdf format at <http://www.pan-tex.net/usr/r/receivers/prodet.pdf>

[3] The QRP Homebuilder site has an excellent page on how to build a diode mixer at <http://www.qrp.pops.net/xmfr.htm>. How to wind the trifilar coils is presented in great detail for those that need help.

[4] “Detailed Description of the Invention”, from reference [1] above, 6<sup>th</sup> paragraph.

[5] “Background of the Invention”, from reference [1] above, 4<sup>th</sup> paragraph.

[6] BG Micro carries a wide selection of colored LEDs, including an excellent super bright blue. Web site is <http://www.bgmicro.com> and email is [tammy@bgmicro.com](mailto:tammy@bgmicro.com)

[7] “Brief Summary of the Invention”, from reference [1] above, last paragraph of the section.

[8] This modification can be seen on the front cover of the Fall 2003 issue of QRP Quarterly ,four brightly- lit blue LEDs in a cluster between an air variable cap and the volume control. <http://www.qrparci.org>

### American QRP Club Forum Schedule for 2004

The American QRP Club is pleased to announce that it will be co- sponsoring the following QRP Forums this year with the following local clubs:

March 26- 27 Atlanticon - NJQRP Club  
 April 9- 10 Ozarkcon - 4 States QRP Club  
 June 18- 19 Hamcom - NORTEX QRP Club  
 July 3- 4 Ft. Tuthill (At Williams, Az) - Az. ScQRPIons  
 July 10- 11 Lobstercon - QRPme  
 October 15- 17 Pacificon - NorCal QRP Club

One of the goals of the AmQRP club was to help provide support for QRP Forums in all areas of the country, so that qrpers would have the opportunity to take advantage of attending one. We did not know how quickly we could start this program, but it is going much faster than we envisioned. We have a model for supporting and putting on QRP Forums, and one of the key parts is funding with kits. You are supporting qrp when you buy kits from clubs, and the clubs could not put on these forums without your help. I hope to make as many of them as possible and look forward to meeting all of you in person. Thanks again for your support. Doug KI6DS

### Farewell QRP-L

This was originally intended to be an obituary to QRP-L, but as I sat and typed I realized that in fact that it was not an obituary... it is a birth notice.

QRPer from all over congregated, tolerated, and yes... sometimes berated on QRP-L for a variety of reasons. Some looked for early notice of contests, events and kits that were qrp “relevant”. Those folks would occasionally ask a question and in most episodes get answers to their questions and the occasional RTFM type response of “haven't you even looked for this answer in the ARRL Handbook?” or “Google... thats spelled G O O G L E!”.

There were true elmers that read, monitored and answered questions on the list also; ask a question about endfed wire dipoles and slinky bazooka's and you would get an answer and probably a heck of a lot of tech data to back it up.

There were the mad scientists of the group there as well... showing off their latest "it fits in a freaking altoids tin and is multiband" wares and doing occasional kit runs, accompanied by much bitching because some folks wanted one after the fact.

There were reviews of equipment and honest dialogue from non company reps about what they really thought about the latest thing.

There were flame wars and feuds, fights and spats... makeup sex and (whoops, maybe not that)

What occurred to me in all of this was that QRP was a big conversation and in that conversation you heard individual voices. Sometimes you thought it was QRM and deleted or filtered it... othertimes you heard cocktail party boasting and bullshit and you deleted and/or filtered that conversation out. But rising above all of that din and cocktail party chatter rose voices of truth. It might not have always been relevant to your needs but someone, somewhere got something out of it.

QRPers will not stop their conversation or their efforts to have a social circle with other likeminded individuals... The party is moving, someone bulldozed the Tavern we used to meet in. That is OK. There are other places to meet. In that meeting place will again be distinct voices in multifaceted conversations. Some of the meeting places might have heavy handed management that will tell the group to keep it down and for gosh sakes "no fighting". Other meetings will occur in places that don't care what we do as long as we don't burn the place down completely.

Folks, QRP-L was a tavern of conversation. Sorry it got bulldozed. Only you can decide wether that was for progress or not.

73 QRP-L  
KD5KXF

## QRP RX – John W2AGN

NOSTALGIA

or

What to do when it's Rreezing Your Piggies Outside

I have built numerous kits. The last biggie was my Multipig Plus #16. (Picture attached). So, I had decided to do more operating. Wouldn't you know the bands decided to be crummy?

About 50+ years ago, when I lived in Philly, we had a BIG snowstorm. I remember we were without electricity for 5 days. My Dad helped me build a Crystal radio, and I had a lot of fun listening to the radio, when nobody else could. (No transistor portables in those days!).

So, we had a couple days of snow, and very cold temperatures here in Vineland, NJ, and I remembered I had bought a Crystal radio kit about 5 years before. I found it, and decided to build a "Deluxe" Version.

The only things I used from the Kit were the Coil Forms, capacitor, and wooden cabinet, which I finished with stain and Marine Spar varnish. I had an old piece of bakelite for the panel, and some old-fashioned banana plugs and jacks for the coil taps. (See schematic).

The receiver is VERY hot on Broadcast Band. I can receive most Philly stations well. The coupling between the antenna couils can be adjusted, and makes it fairly selective (for a crystal radio!).

It also receives SW Broadcast up to about 8 Mhz. I have copied the BBC with it late at night, using an antenna tuner to tune my 300' loop.

Mostly, it's about nostalgia....

John W2AGN

W2AGN's beautiful craftsmanship!





**OUR MISSION:**

- 1: Have Fun.
- 2: No rules.
- 3: Have a group of Friendly Hams who enjoy Amateur Radio, and sharing their skills with their fellow Hams.

**CLUB EMAIL POLICY:**

These are not rules, just common sense. Club email is not moderated, as we are not a stuffy group. You can send off topic messages about most subjects, but please keep it clean and in good taste. We do like good-natured ribbing and joking with each other, but we will not tolerate flaming other members or spamming the group. We will remove offenders who abuse our open policy.

**CLUB WEB PAGE:**

The club web page is our forum for sharing projects, and information about us. You are encouraged to submit your ideas and projects to be added to the web page.

**PROBLEM REPORTING:**

If you are having problems with email, the web page, or a fellow club member, please report this to either: Diz, W8DIZ at [w8diz@cinci.rr.com](mailto:w8diz@cinci.rr.com) Rick, WB6JBM at [ripowell@mpna.com](mailto:ripowell@mpna.com) Dan, N8IE at [n8ie@who.rr.com](mailto:n8ie@who.rr.com) We welcome all to join the Flying Pigs QRP Club, and we hope you have fun! Ω



Top view of the QRP RX  
Schematic is on page 8

**About the Flying Pigs QRP Club International**



John's Awesome Multipig!!!!

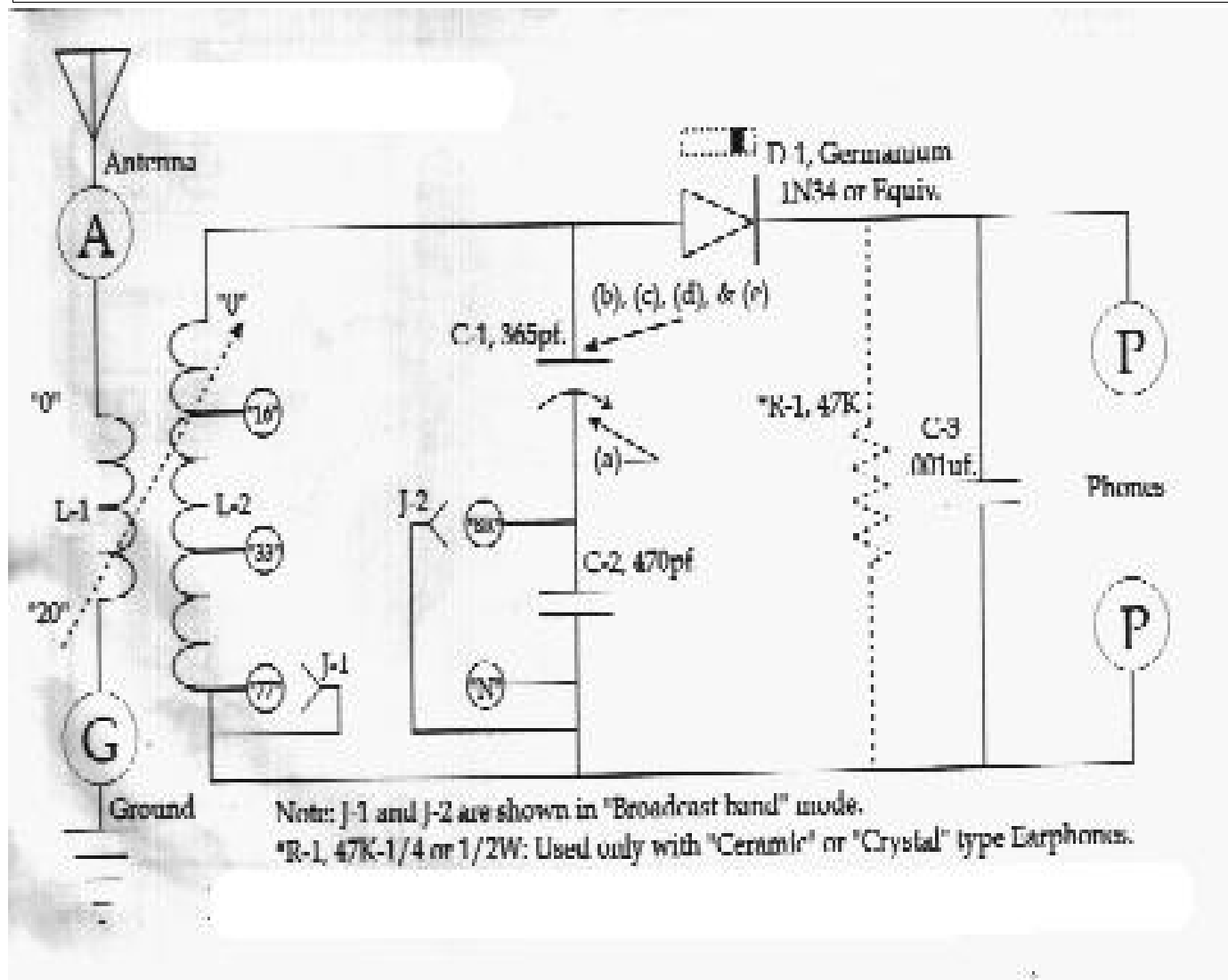

Schematic for W2AGN's QRP RX